

T10

Codice testa
Head code

Codice mandrino
Spindle code

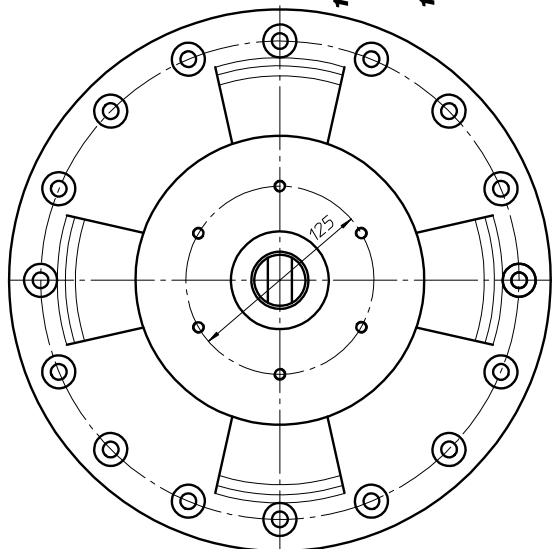
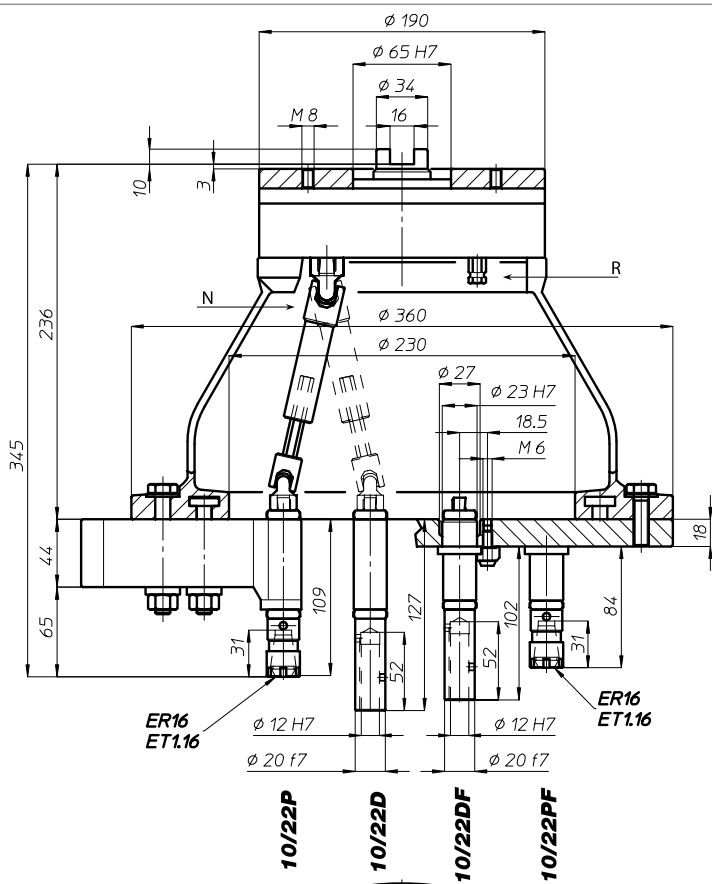
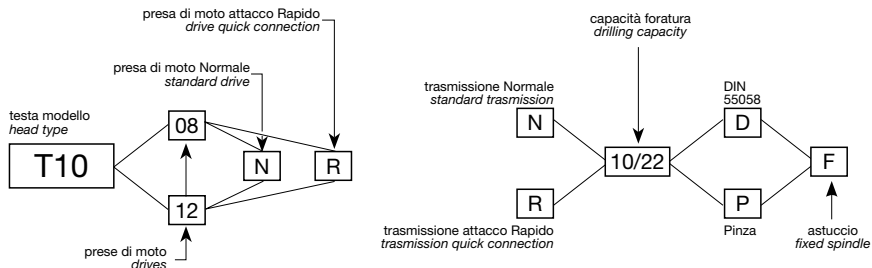

N° prese di moto
Nr. spindle drives

08-12

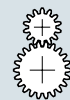

Rapporto
Ratio

1-1



Capacità di foratura
Drilling capacity
acciaio R=500 N/mm²
ghisa: GG25

8
10



Maschiatura
Tapping

M6



Attacco utensile
Type of spindle

D

P

DIN 55058 Ø12
ER16



Peso gruppo testa
Head weight

Kg 12



Peso gruppo mandrino
Spindle-set weight

Kg 1,5

area di lavoro
working area

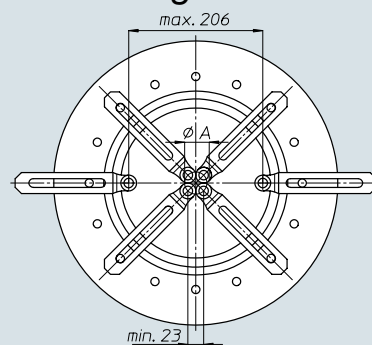

ø A

n° mandrini
n° spindles

27	3
33	4
39,5	5
46,5	6
53,5	7
60,5	8
67,5	9
75	10
82	11
89,5	12



BAH

TA.CP

TA

MO

HT

VH

TSI/TSX

T

MT-TC-TC3

Accessori
Accessories

Appendice tecnica
Technical supplement

8-5