

T7

Codice testa
Head code

Codice mandrino
Spindle code

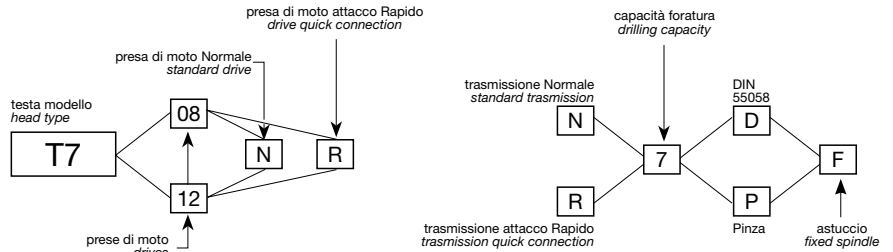

N° prese di moto
Nr. spindle drives

08-12



Rapporto
Ratio

1-1



Capacità di foratura
Drilling capacity
acciaio R=500 N/mm²
ghisa: GG25

6
7

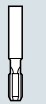

Maschiatura
Tapping

M5



Attacco utensile
Type of spindle

D
P

DIN 55058 Ø10
ER11



Peso gruppo testa
Head weight

Kg 10



Peso gruppo mandrino
Spindle-set weight

Kg 1,1

area di lavoro
working area

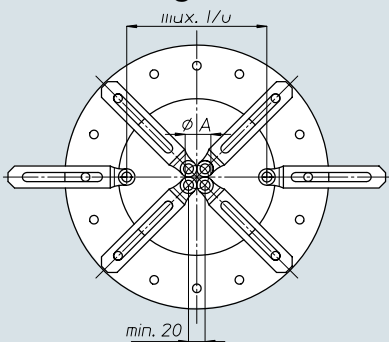

max. l/u

min. 20

ø A

n° mandrini
n° spindles

ø A	n° mandrini n° spindles
23,5	3
28,5	4
34,5	5
40,5	6
46,5	7
52,5	8
59	9
65,5	10
71,5	11
77,5	12

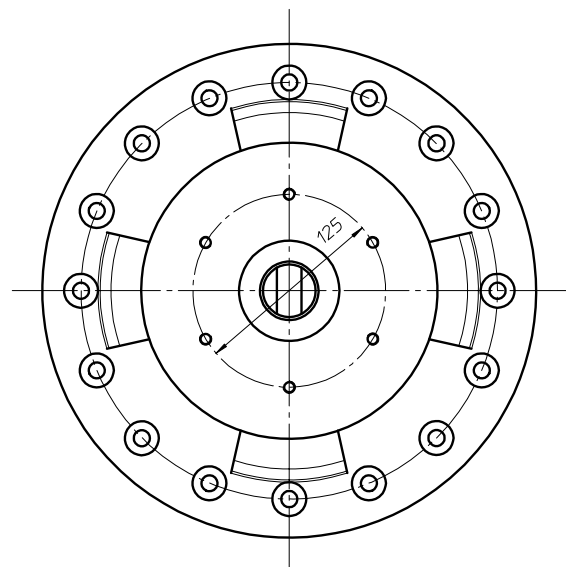
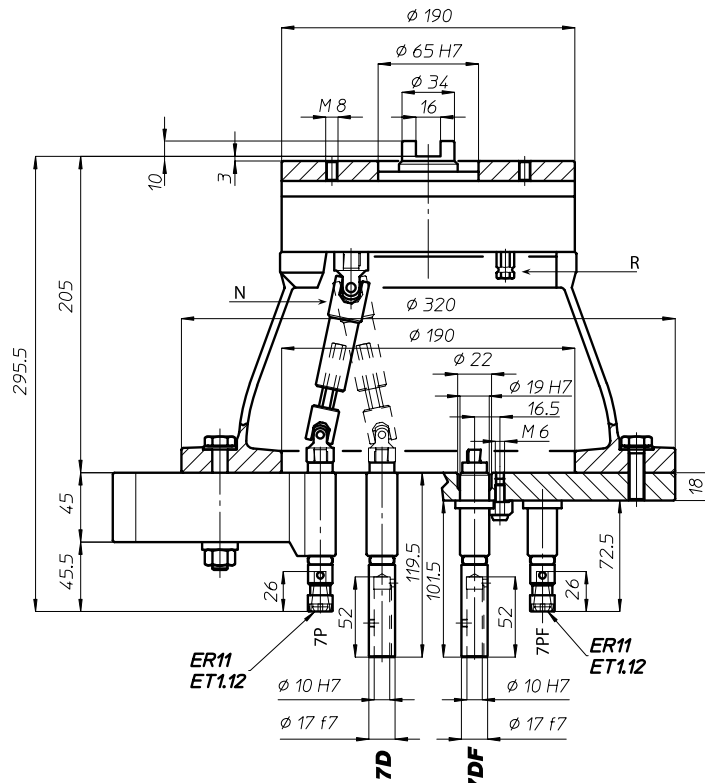

BAH

TA-CP

TA

MO

HT

VH

TSI/TSX

T

MT-TC-TC3

Accessori
Accessories

Appendice tecnica
Technical supplement

8-4

