

# TR8/22

Codice testa  
Head code

Codice mandrino  
Spindle code

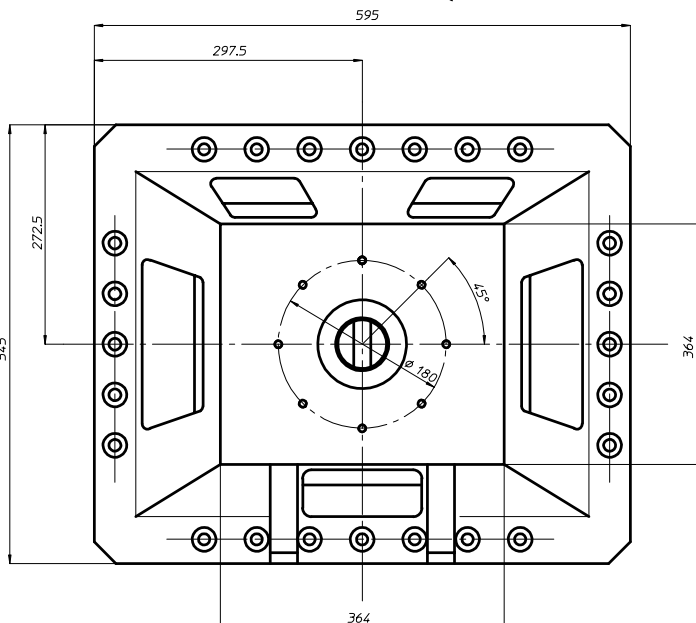
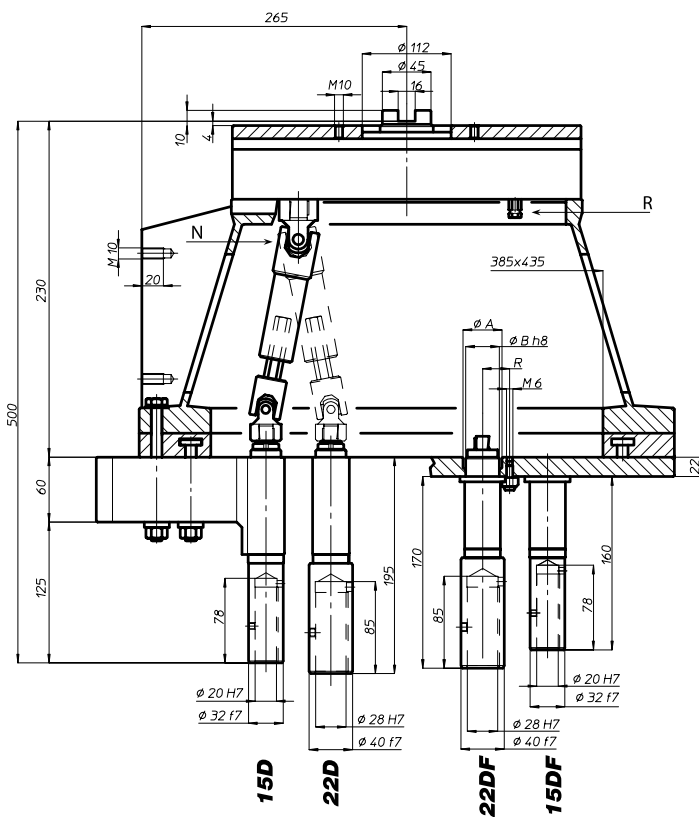
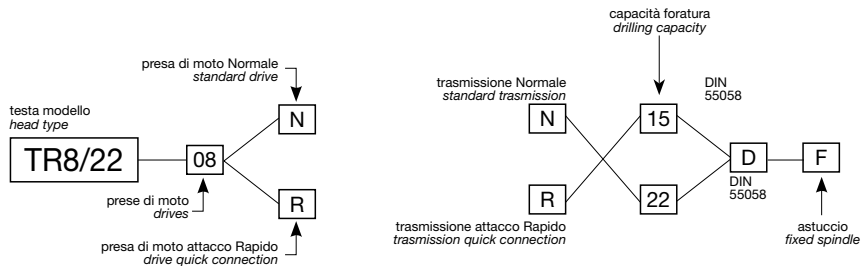

N° prese di moto  
Nr. spindle drives

12



Rapporto  
Ratio

1-1,5



Capacità di foratura  
Drilling capacity  
acciaio R=500 N/mm<sup>2</sup>  
ghisa: GG25

15D: 13 22D: 20  
15D: 15 22D: 22

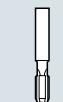

Maschiatura  
Tapping

15D: M12  
22D: M16



Attacco utensile  
Type of spindle

D DIN 55058  $\phi 20$ - $\phi 28$

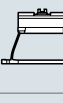

Peso gruppo testa  
Head weight

Kg 86



Peso gruppo mandrino  
Spindle-set weight

15D: Kg 4  
22D: Kg 5,5

area di lavoro  
working area

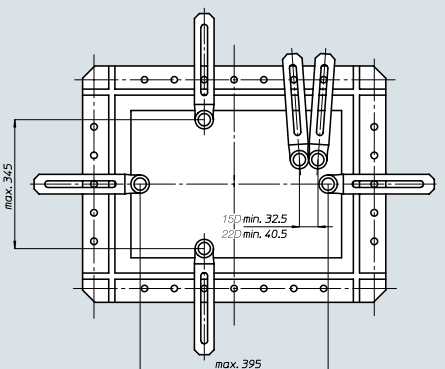

BAH

TA-CP

TA

MO

HT

VH

TSI/TSX

T

MT-TC-TC3

Accessori  
Accessories

Appendice tecnica  
Technical supplement