

CAPACITA' FORATURA
DRILLING CAPACITY $\phi 5$

VH

modello 04

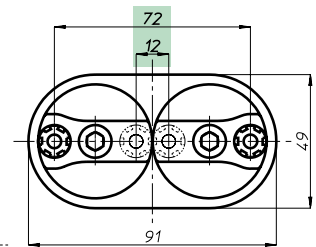
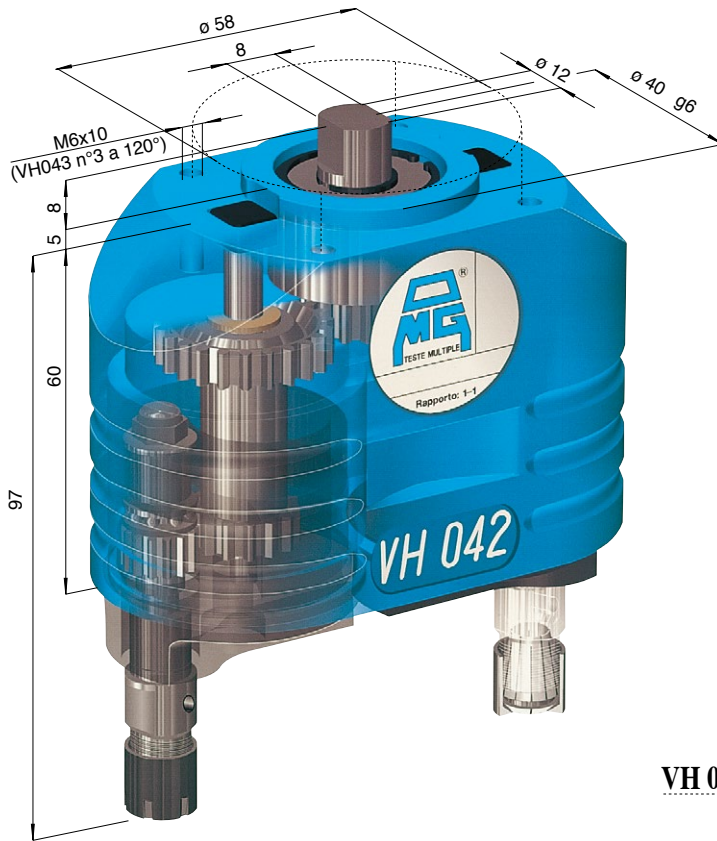

VH 042

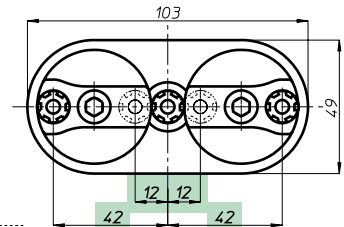

VH 043 L

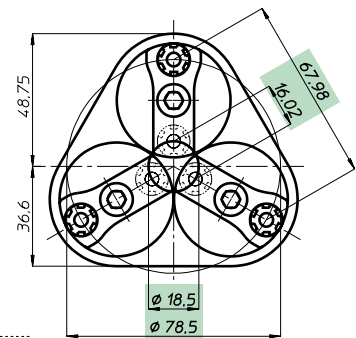

VH 043

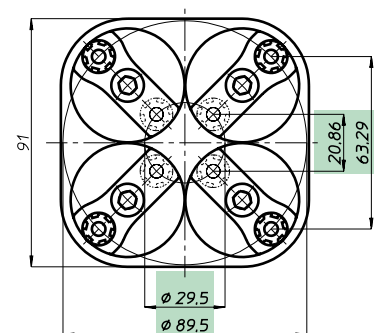

VH 044

Testa modello Head type	VH 042	VH 043 L	VH 043	VH 044
Articolo Item	VH 042 PV	VH 043 LP	VH 043 P	VH 044 P
Attacco utensile Spindle type	ER 8 - max $\phi 5$			
Articolo Item				
Attacco utensile Spindle type				
N. mandrini Spindles nr.	2	3	3	4
Campo di lavoro min.	12	12 + 12	$\phi 18,5$	$\phi 29,5$
Centre distances max.	72	42 + 42	$\phi 78,5$	$\phi 89,5$
Capacità foratura Drilling capacity	Acciaio Rm 500 N/mm ² - $\phi 4$			
Maschiatura Tapping	Ghisa GG25 - $\phi 5$			
Rapporto Ratio	M 3			
Velocità RPM	1 - 1			
Peso Weight	0,95	1,05	1,4	1,9

Teste multiple ad assi variabili • Variable axis heads

BAH

TA-CP

TA

MO

HT

VH

TSI/TSX

T

MT-TC-TC3

Accessori
Accessories

Appendice tecnica
Technical supplement

6-2

