

CAPACITA' FORATURA
DRILLING CAPACITY ϕ 28

VH

modello 25

Teste multiple ad assi variabili • Variable axis heads

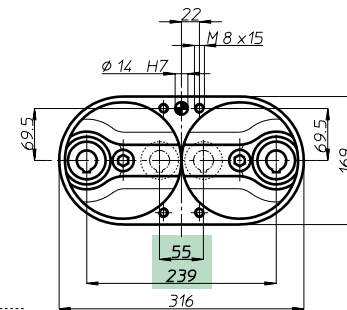
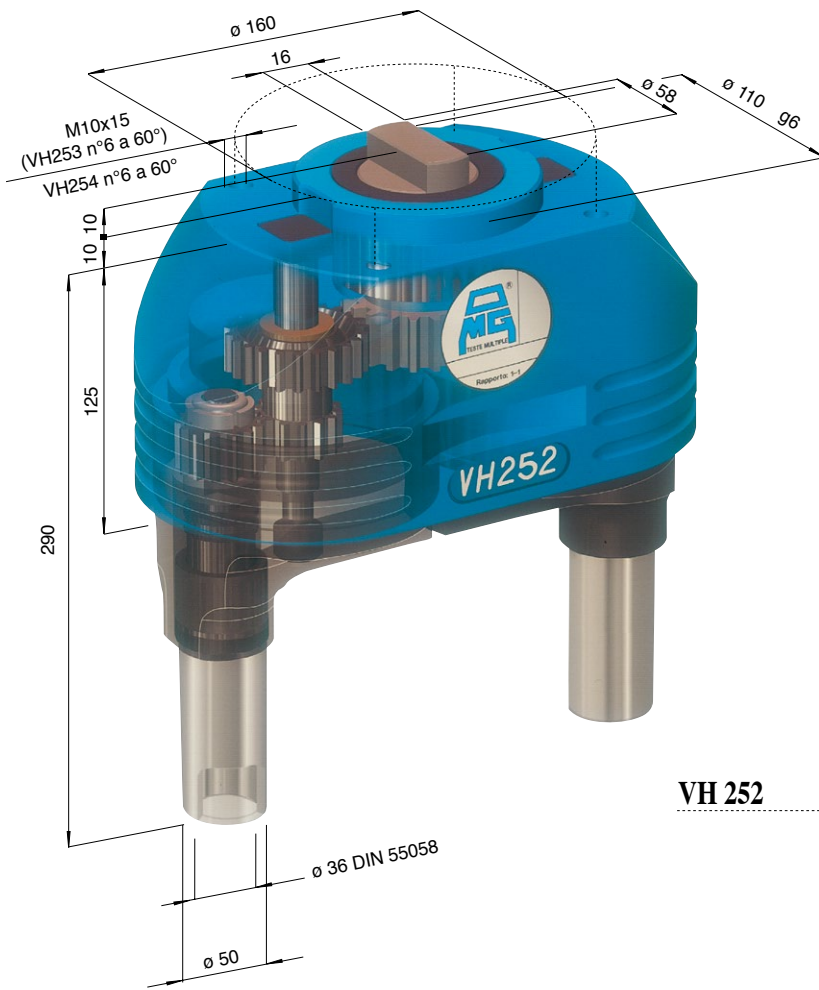

VH 252

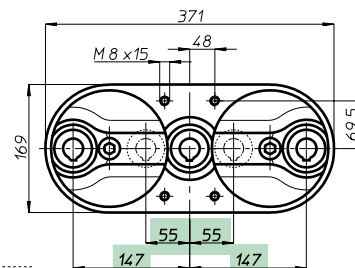

VH 253 L

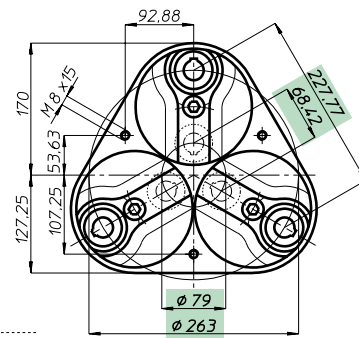

VH 253

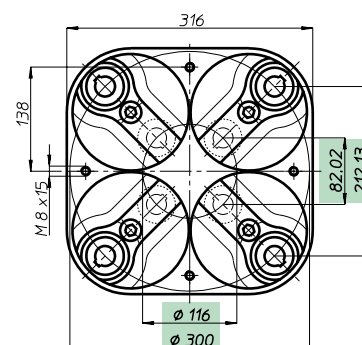

VH 254

Testa modello Head type	VH 252	VH 253 L	VH 253	VH 254
Articolo Item				
Attacco utensile Spindle type	DIN 55058 - ϕ 36			
Articolo Item	VH 252 D	VH 253 LD	VH 253 D	VH 254 D
Attacco utensile Spindle type	DIN 55058 - ϕ 36			
N. mandrini Spindles nr.	2	3	3	4
Campo di lavoro min.	55	55 + 55	ϕ 79	ϕ 116
Centre distances max.	239	147 + 147	ϕ 263	ϕ 300
Capacità foratura Drilling capacity	Acciaio Rm 500 N/mm ² - ϕ 25			
Maschiatura Tapping	Ghisa GG25 - ϕ 28			
Rapporto Ratio	M 20			
Velocità RPM	1 - 1			
Peso Weight	27	32	39,5	52

BAH TA-CP TA MO HT VH TSI/TSX T MT-TC-TC3 Accessori Accessoirés Appendice tecnica Technical supplement

