

T2

Codice testa
Head code

Codice mandrino
Spindle code

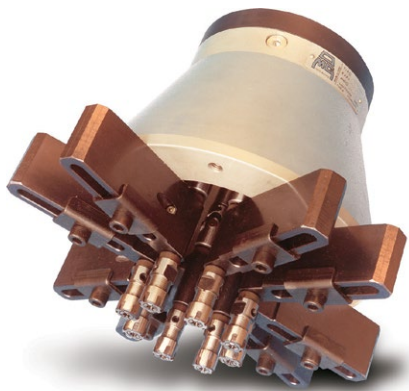

N° prese di moto
Nr. spindle drives

08

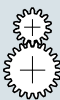

Rapporto
Ratio

1-1



Capacità di foratura
Drilling capacity

4



Maschiatura
Tapping

M4



Attacco utensile
Type of spindle

ER8



Peso gruppo testa
Head weight

Kg 3,25



Peso gruppo mandrino
Spindle-set weight

Kg 0,3

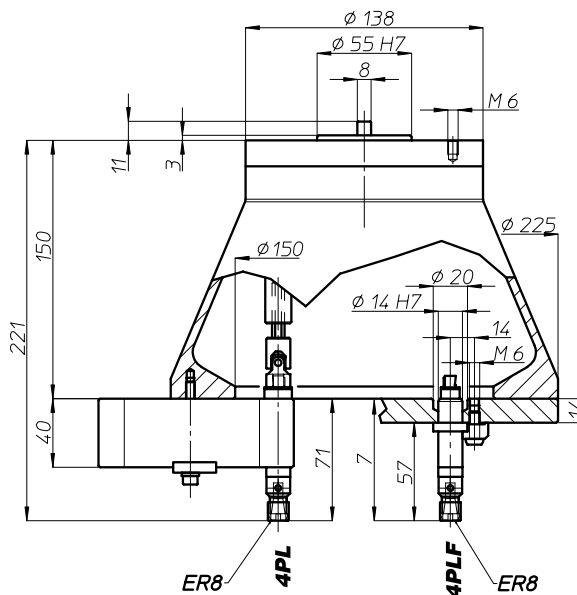
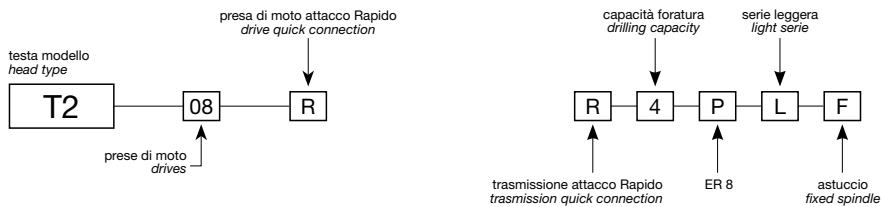

area di lavoro
working area

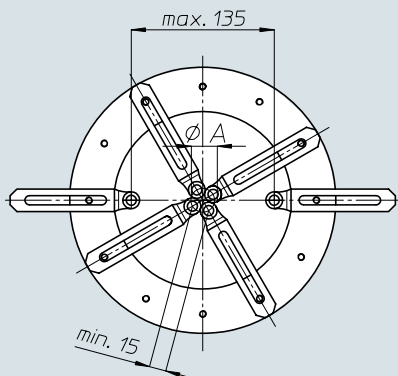

Ø A	n° mandrini n° spindles
15	2
17,5	3
21,5	4
26	5
30	6
35	7
39,5	8

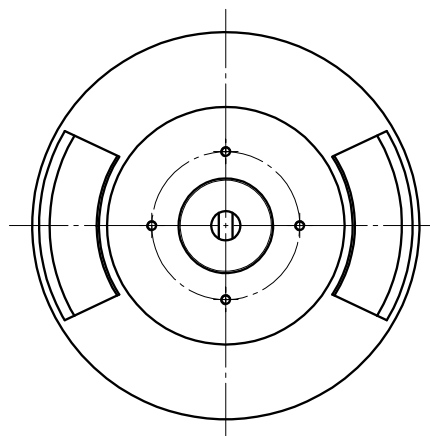

BAH

TA-CP

TA

MO

HT

VH

TSI/TSX

T

MT-TC-TC3

Accessori
Accessories

Appendice tecnica
Technical supplement

8-2

