

TL40/12

Codice testa
Head code

Codice mandrino
Spindle code

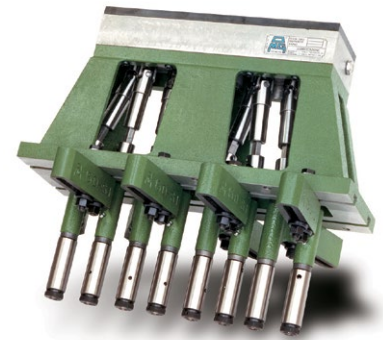
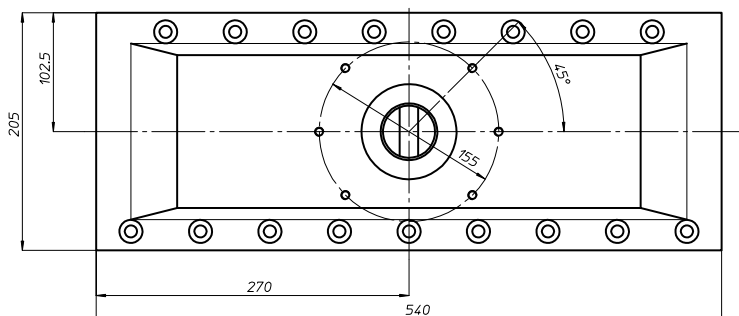
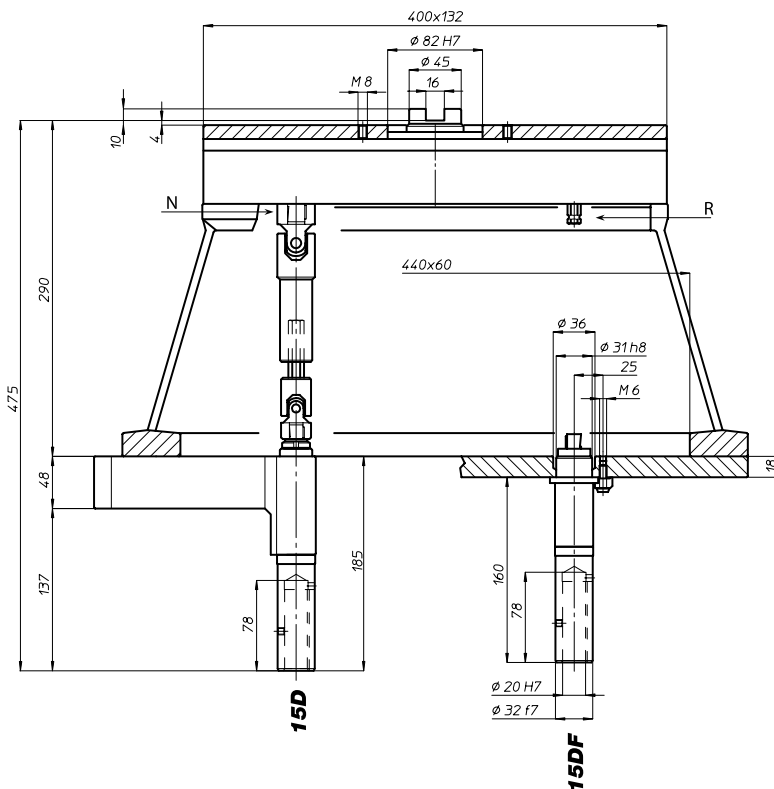
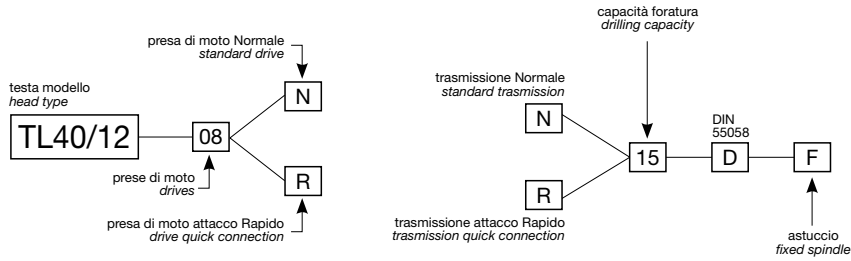

| | | |
|--|---|---------------|
| | N° prese di moto Nr. spindle drives | 08 |
| | Rapporto Ratio | 1-1 |
| | Capacità di foratura Drilling capacity acciaio R=500 N/mm ² ghisa: GG25 | 13 15 |
| | Maschiatura Tapping | M12 |
| | Attacco utensile Type of spindle D | DIN 55058 Ø20 |
| | Peso gruppo testa Head weight | Kg 25 |
| | Peso gruppo mandrino Spindle-set weight | Kg 2,5 |

area di lavoro
working area

